

# TIF TRIFLOW CONCEPTS



DELIVERING FILTERED,  
BOILING AND O3 WATER

# TRIFLOW CONCEPTS

## Tap into a Healthy Lifestyle

Triflow Concepts are excited to further develop our product range in 2024.

Our new 3 in 1 and Hybrid Pro boiling tap systems combine the latest in heater technology with Triflow's ongoing commitment to providing the freshest and healthiest water possible.

They feature a wide range of finishes to suit any household, and provide an excellent value for money solution for your boiling tap requirements.

Triflow Concepts continue to be at the forefront of new tap innovation through our O3 range, producing anti-bacterial water through a touch of a button or motion sensor in a variety of award-winning designs.

For full details please visit our dedicated website, [triflowO3.com](http://triflowO3.com).

Triflow's mission is to provide an outstanding customer experience for all our products and we look forward to supplying you with the best filtered water!

*Triflow Concepts*



-  [triflowconcepts.com](http://triflowconcepts.com)
-  [facebook.com/TriflowConceptsLtd](https://facebook.com/TriflowConceptsLtd)
-  [info@triflowconcepts.com](mailto:info@triflowconcepts.com)
-  0800 999 3959



# TRIFLOW 3-IN-1

Product Code: TF-3IN1



### KEY FEATURES:

- **NEW for 2024!**
- 3 in 1 System.
- Boiling, Hot and Cold water on demand.
- WRAS Approved System.
- 3-in-1 system comes with a Limescale filter as standard.
- Child lock control on boiling water switch.
- Cold to touch design.
- 360 degree rotating spout.

Available in: Brushed Nickel



Matt Black



Chrome

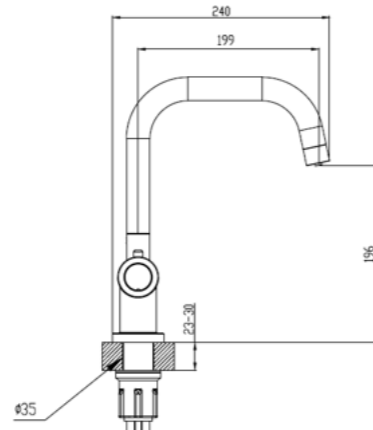
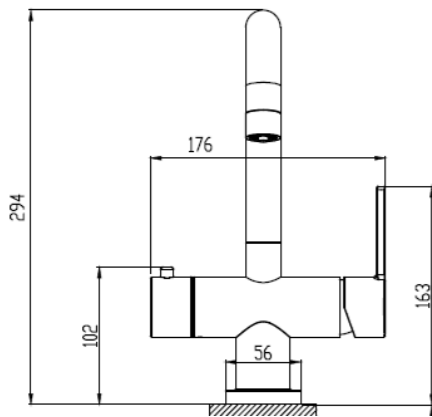

# 3-in-1 HEATER TANK



### KEY FEATURES:

- WRAS Approved.
- Adjustable temperature control.
- Non pressurised Heater Tank.
- Heater Tank has 2.5 Litre capacity.
- Compact design to fit easily under any sink.
- Supply pressure (Min) 1.0 bar.
- Supply pressure (Max) 5.0 bar.

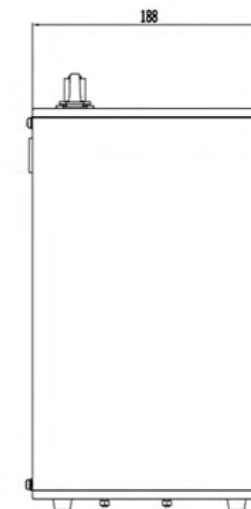
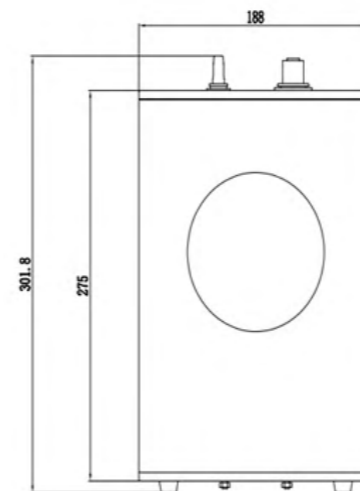

# TRIFLOW HYBRID PRO

Product Code: TF-PRO



## KEY FEATURES:

- **NEW for 2024!**
- 4 in 1 System
- Boiling, Hot and Cold, Filtered water on demand by LED touch control.
- Dedicated waterway for filtered water to avoid cross-contamination.
- Hybrid system comes with TF1000 Limescale filter as standard.
- Option to add Katadyn high performance drinking filter.

Available in: Black



Chrome



Gunmetal



Stainless Steel

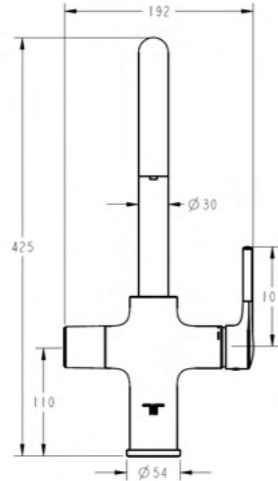
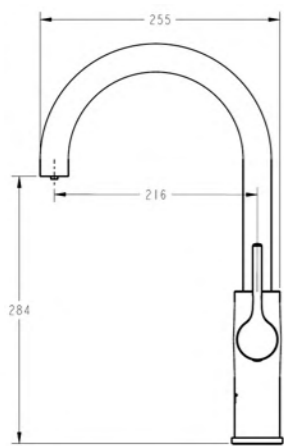

# HYBRID HEATER TANK



## KEY FEATURES:

- Heater Tank has 3 Litre capacity.
- Compact design to fit easily under any sink.
- 4 Temperature settings, perfect for tea and coffee.
- Touch control.
- Pressure reducing valve.
- Pump safety stop to prevent dry running.
- Dry start and boil dry prevention.
- Supply pressure (min) 1.0 bar.
- Supply pressure (max) 3.0 bar.

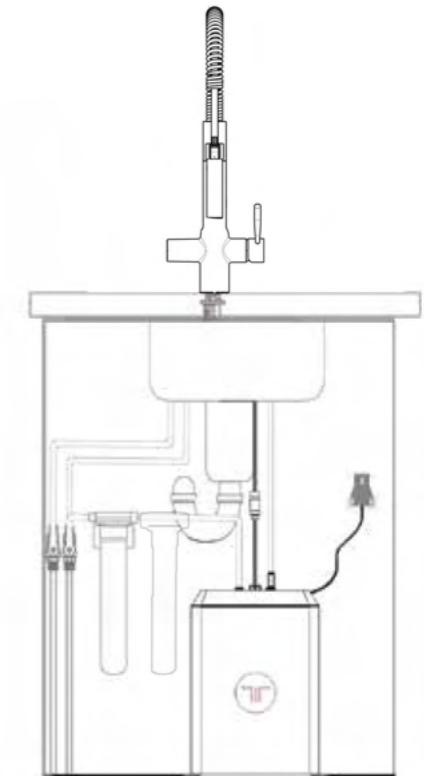



# TRIFLOW HYBRID FLEX

Product Code: TF-KT-HYBRID



## KEY FEATURES:

- 4 in 1 System.
- Boiling, Hot and Cold, Filtered water on demand by LED touch control.
- Pull out spray head.
- Dedicated waterway for filtered water to avoid cross-contamination.
- Hybrid system comes with TF1000 Limescale filter as standard.
- Option to add Katadyn high performance drinking filter.

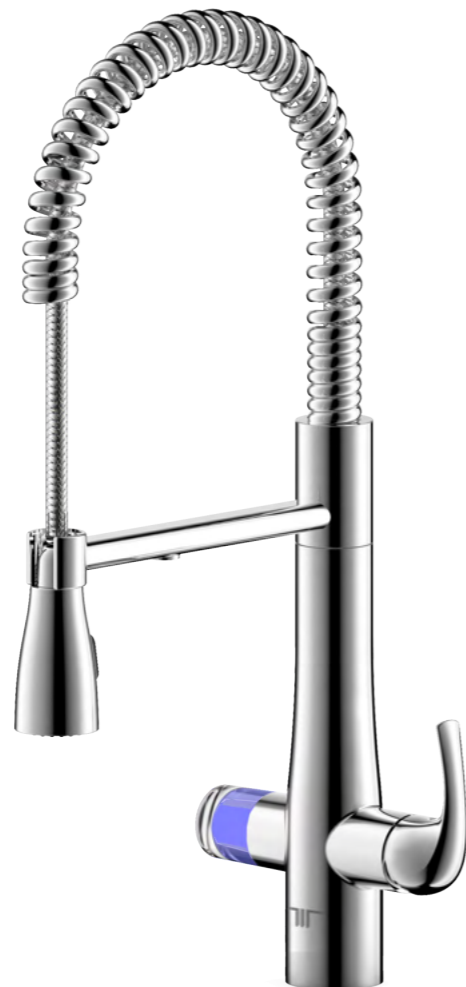
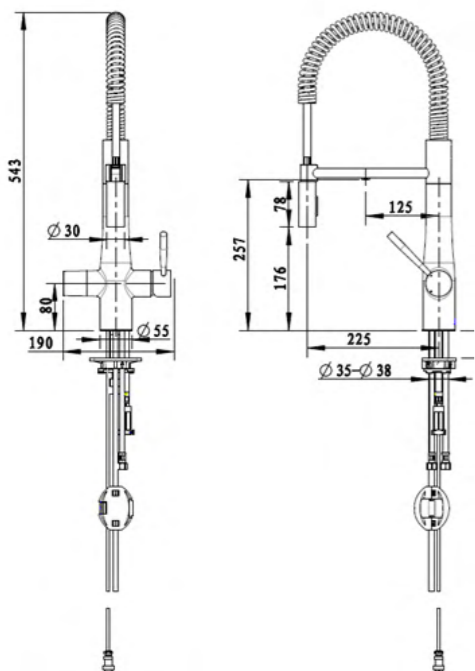

# TRIFLOW O3 WATER

## How is O3 water made?

Ozone is a natural gas, a tri-atomic form of Oxygen.

It is produced in the Ozone Generator which is supplied with air and a little bit of electricity.

The electricity splits the Oxygen in the air into two Oxygen atoms. The Oxygen atoms combine with Oxygen molecules to form the Ozone gas.

The weak bond holding Ozone's third Oxygen atom is what causes Ozone to be a very strong Oxidant and an ideal 'Chemical free' sanitizer and oxidizer agent.

When oxidizing a compound, it loses the weakly bonded atom, and an oxygen molecule remains.



## O3 Anti-Bacterial Properties

O3 is 3,000 times more powerful than traditional oxidants such as chlorine. It has no toxicity issues and produces no by products. Micro-organisms do not build up a tolerance to O3. O3 can eliminate a wide variety of inorganic, organic, microbiological, taste and odour problems.

The efficacy of Triflow O3 Water to destroy pathogens is dependent on the O3 concentration in water and the contact or 'treatment' time. The sanitizing ability of Triflow O3 Water increases as either or both variable is increased.

Independent testing by Internationally recognised Labs such as TÜV have upheld all claims made on the NEW Triflow O3 systems.

## Safety

O3 is produced in the Generator; because of its 'short life' (as it reverts back to Oxygen). O3 cannot be supplied or stored in tanks.

O3 has been allowed and accepted in food processing in many countries including Japan, Australia and New Zealand. O3 was confirmed by FDA in 1998 as a safe and sustainable sanitizer for food.

## O3 Benefits

- Over 99.99% of microbes and viruses will be removed
- Leaving you with clean hands and surfaces with no chemicals required
- Removes odours from fish, garlic, smoke, etc, just with Ozonized water
- O3 water can preserve food for up to 2-3 times longer
- Simply press the O3 button or activate the sensor to start dispensing O3 water
- No change in the water flow rate or temperature
- The O3 generator will automatically stop if not used for more than 10 mins
- 2 Years Guarantee on both Generator and Tap

## O3 Approvals

O3 is approved by the Food and Drug Administration in the USA. All components in Triflow O3 Taps are WRAS compliant.



## O3 Awards

Triflow O3 has already gained the following design awards



## IDEA Design

Award - Gold Winner



# TRIFLOW O3 MIXER

Product Code: TF-03-KITCHEN



## KEY FEATURES:

- 3 in 1 system incorporating Hot, Cold and O3 water.
- O3 water by the touch of a button.
- Pull out spray head.
- 360-degree rotating spout.
- Solid brass construction with deep protective coating.
- Available in Chrome.

## Generator

- Slimline design.
- Mains power operated.
- Space saving installation feature.

# TRIFLOW O3 SENSOR

Product Code: TF-03-SENSOR



## KEY FEATURES:

- O3 specific system.
- Motion infrared sensor activation.
- Solid brass construction with deep protective coating.
- With temperature control.
- Available in Chrome.

## Generator

- Slimline design.
- Mains power operated.
- Space saving installation feature.

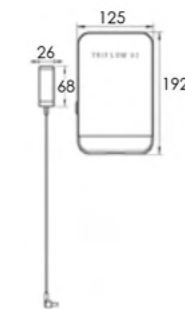
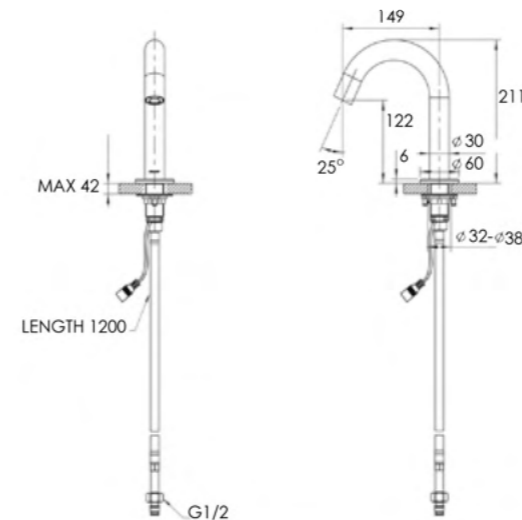
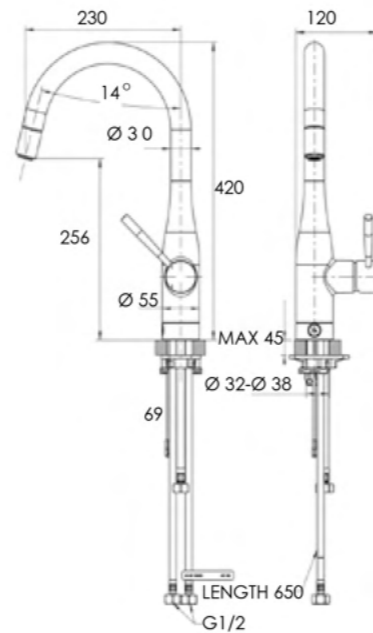
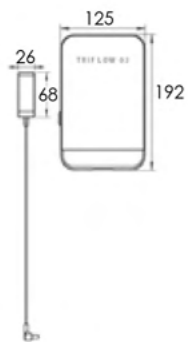



# TRIFLOW FILTER TECHNOLOGY

*It's time to enjoy the freshest drinking water with the industry's most effective filters*

Katadyn exclusively manufacture the TFE500, TF321, TF160 and TRX160 filters for Triflow Concepts. The Swiss company have been involved with water treatment since 1928 and their products, which are used all over the world, are renowned for their consistency and reliability.

The Swiss-made filters implement a four stage filter process which significantly reduces impurities as well as retaining important minerals:

- **0.2 micron pore sintered ceramic**
- **Anti-bacterial silver impregnated ceramic**
- **Activated carbon core**
- **Zeolite**

Katadyn filters have the capability in one small unit to remove and reduce:

- Pathogenic bacteria
- Chlorine
- Taste
- Cysts
- Organics
- Odour
- Turbidity
- Heavy metals
- Colour
- Micro-Plastics

This advanced filter technology enhances the taste and smell of your drinking water, ensuring every glass is fresh.

## Advanced technology

The outer shell of the cartridge is made of a high quality, micro-porous, silver impregnated, ceramic structure which traps out silt, debris, pathogenic bacteria and protozoan cysts. With a pore size so small, the cartridge is able to reduce particles down to 0.2 microns in size.

The activated carbon within the core of the Katadyn ceramic, is effective in eliminating chemicals and impurities that contribute to bad taste and odour. As water passes through the ceramic wall and over the slightly positively charged carbon surface, organic contaminants in the water diffuse into the structure of the carbon granules and are absorbed. The TF321 and TFE500 filters are sized so that they will treat a normal domestic water application for at least six months.

A pulverised synthetic zeolite is intermixed with the activated carbon prior to its extrusion. Zeolite is used to absorb and reduce up to 98% of lead present in water.

# FILTER RANGE

For the best quality and freshest drinking water, we recommend that you change your filter every six months. After this period, the activated carbon becomes less efficient in absorbing material and you may notice a reduction in the flow rate of water.



### TFE500 Filter Cartridge

**Push fit**, 4 stage ceramic filter, exclusively manufactured for Triflow by Katadyn Inc Switzerland.

- Standard filter with all new Triflow taps
- Manufactured from survival grade materials
- Removes 99.99% of bacterial pathogens
- Silver impregnated to stop bacteria growth
- Active carbon improves taste and odour
- Reduces heavy metals inc. lead
- Each filter is individually quality checked



### TF321 Filter Cartridge

**Screw fit**, 4 stage ceramic filter, exclusively manufactured for Triflow by Katadyn Inc Switzerland.

- Manufactured from survival grade materials
- Removes 99.99% of bacterial pathogens
- Silver impregnated to stop bacteria growth
- Active carbon improves taste and odour
- Reduces heavy metals inc. lead
- Each filter is individually quality checked



### TF1000 Filter Cartridge

Limescale Carbon Activated filter, exclusively manufactured for Triflow.

- Works to remove Limescale from the Heater Tank
- Active carbon improves taste and odour
- 0.5 Micron filter level
- 90% Chlorine removal
- Advised to replace every 6 months.



### TRX160 Filter Cartridge

**Push fit** filter, exclusively manufactured for Triflow by Katadyn Inc Switzerland.

- 1 micron outer surface to remove large particles
- Active carbon improves taste & odour
- Reduces heavy metals inc. lead
- Ideal alternative for low pressure areas



### TF160 Filter Cartridge

**Screw fit**, solid carbon block filter, exclusively manufactured for Triflow by Katadyn Inc Switzerland.

- 1 micron outer surface and 0.5 micron insidet to remove large particles
- Active carbon improves taste & odour
- Reduces heavy metals inc. lead
- Ideal alternative for low pressure areas

### Filter Replacement Service

With this convenient service, you never have to worry about losing track of your next filter renewal.

By signing up to our direct debit scheme, you will have the freshest water delivered to you automatically every six months.

[triflowconcepts.com/direct-debit](http://triflowconcepts.com/direct-debit)

With your first automated cartridge replacement order, you will receive a complimentary 500ml stainless steel Triflask, worth £19.99.

# TRIFLOW ORIGINAL WHITEHALL

Product Code: TF-KT32C



## KEY FEATURES:

- Filter, Hot & Cold water system.
- An elegant timeless design to suit all kitchen trends.
- 360° rotating spout.
- Solid brass construction with a deep protective coating.
- Durable stainless steel housing.
- Including advanced Katadyn ceramic filtration system.
- Available with a separate rinse please see website.

Available in:



Chrome



Nickel



Pewter

Also available



U Spout  
TF-KT32U

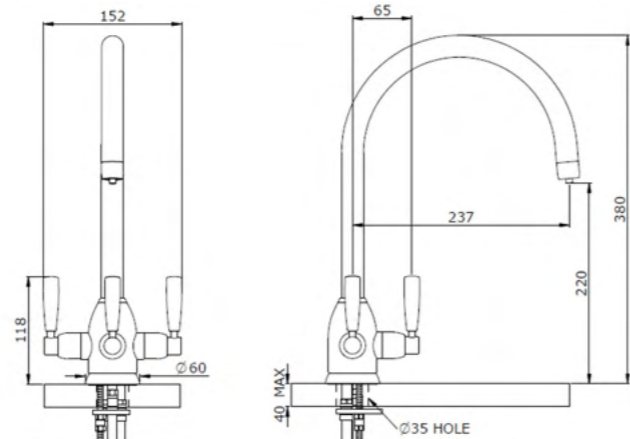

# TRIFLOW ORIGINAL CHURCHILL

Product Code: TF-KT33C



## KEY FEATURES:

- Filter, Hot & Cold water system.
- Rounded body which complements a refined design.
- 360° rotating spout.
- Solid brass construction with a deep protective coating.
- Durable stainless steel housing.
- Including advanced Katadyn ceramic filtration system.
- Available with a separate rinse please see website.

Available in:



Chrome



Nickel



Pewter

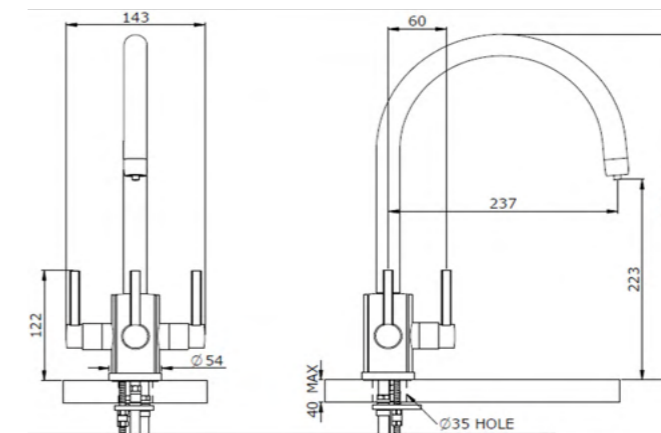



# TRIFLOW ORIGINAL NEWTON

Product Code: TF-KT34U



## KEY FEATURES:

- Filter, Hot & Cold water system.
- The tallest of our range, perfect for double sinks.
- 360° rotating spout.
- Solid brass construction with a deep protective coating.
- Durable stainless steel housing.
- Including advanced Katadyn ceramic filtration system.
- Available with a separate rinse please see website.

Available in:



Chrome



Nickel



Pewter

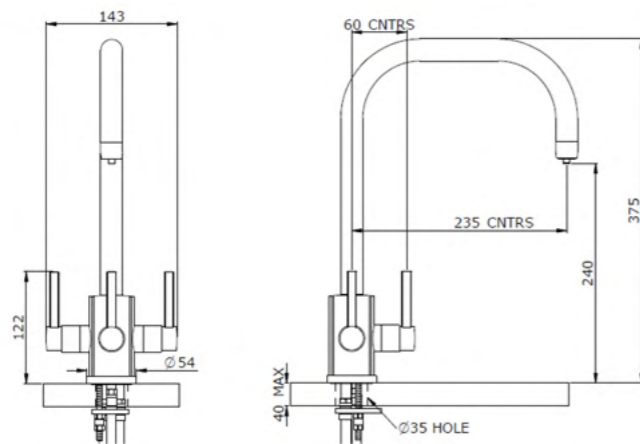

# TRIFLOW ORIGINAL LIVINGSTONE

Product Code: TF-KT40C-CP



## KEY FEATURES:

- Filter, Hot & Cold water system.
- A modern reflection on a vintage British classic
- 360° rotating spout.
- Solid brass construction with a deep protective coating.
- Durable stainless steel housing.
- Including advanced Katadyn ceramic filtration system.

Available in:



Chrome

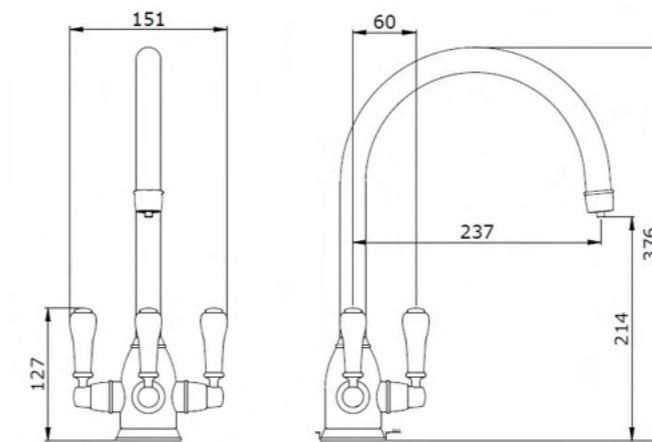

# TRIFLOW MINI



Product Code:  
TF-MINI-BLACK



Product Code:  
TF-MINI-GREY



Product Code:  
TF-MINI-RED

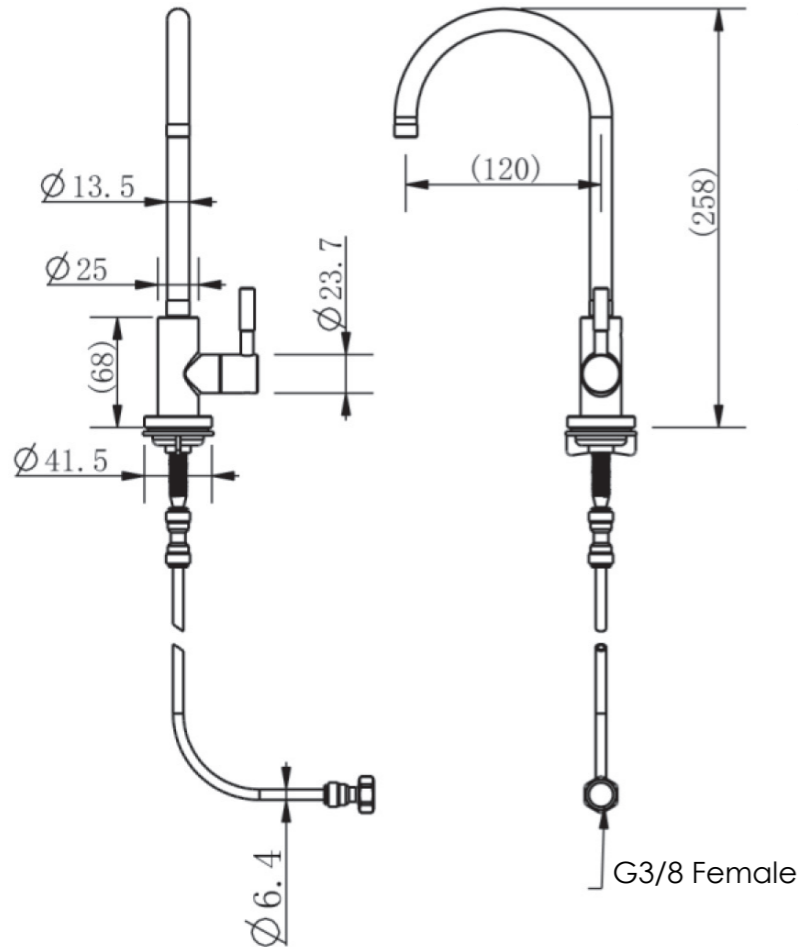

Diameter of hole: 12-35mm

The Triflow Mini comes complete with our push fit stainless steel housing and a TFE500 Filter giving you great tasting water in a new compact design.

The Triflow Mini has a handy flexible spout so you are able to manipulate the spout direction and shape to suit your needs.

Available in 3 individual spout colours: **Black, Grey and Triflow Red.**

# FILTER HOUSING



## Stainless Steel Filter TF104S Housing for Push Fit

Product Code: TF104S

- High grade 304L stainless steel cylinder with push fit cap
- Slim-line and compact unit, fitting neatly under the worktop
- Easy to install filter with push fit function
- Quarter turn bayonet housing
- Push fit removes the risk of over tightening the filter
- Includes connections, braided hoses, wall bracket and fitting instructions
- Compatible with TFE500 and TRX160 Filters



## Stainless Steel Filter TF103S Housing for Screw Fit

Product Code: TF103S

- High grade 304L stainless steel cylinder with screw fit cap
- Slim-line and compact unit, fitting neatly under the worktop
- Quarter turn bayonet housing
- Includes connections, braided hoses, wall bracket and fitting instructions
- Compatible with TF321 and TF160 filters

# Triflask



- Our new Triflask is a vacuum bottle that keeps your cold drinks cool for up to 24 hours and your hot drinks piping for up to 12 hours!
- The reusable 500ml bottle uses the latest insulated technology meaning your drinks will always stay fresh
- The modern design of the Triflow Triflask is complemented with a powder coated finish to provide extra durability and grip when in use
- Supplied with a leak proof screw on lid
- Made from high-quality 304 grade stainless steel to preserve the flavour and taste of your drink during the day

# Service & Warranty

## Our Promise to You

Our products are manufactured utilising industry leading quality and design. If a call out is required for servicing, assistance or installation, you can rest assured that our team will arrange a fully trained engineer to complete this at a convenient time for you.

## Triflow Original System

Our products are manufactured utilising industry leading technology, quality and design. Your Triflow tap is guaranteed by Triflow Concepts against any manufacturing defect for a period of 5 years. The filter housing has a warranty of 2 years from the date of purchase. The surface finish of Triflow products is guaranteed for 1 year from the date of purchase.

Please note for the Original Systems your warranty is conditional on Triflow Water Filter being replaced every 6 months,

## Triflow O3 / Hybrid / 3-in-1 and Mini Systems:

All parts are guaranteed by Triflow Concepts against any manufacturing defects for a period of 2 years from date of purchase. The surface finish is guaranteed from 1 year from date of purchase.

Please note for the Hybrid and 3-in-1 Systems your warranty is conditional on the Triflow TF1000 filter being replaced every 6 months, to prevent Limescale build up in the tank.

For more details on how to register your warranty, visit the support section at [triflowconcepts.com](http://triflowconcepts.com)

# SPECIFICATIONS

	Tap Name	Tap Model	Tap Height	Spout Reach	Base Diameter	Tap Cut - Out Diameter	Finish
3-in-1	 Triflow 3-in-1	TF-3IN1	294	199	56	35	Chrome Black Nickel
	Triflow Hybrid Pro	TF-PRO	425	216	54	35	Chrome S.Steel Black Gunmetal
HYBRID	Triflow Hybrid Flex	TF-KT-HYBRID	543	225	55	35	Chrome
	O3 Sensor	TF-O3-SENSOR	211	122	60	30	Chrome
O3	O3 Kitchen Mixer	TF-O3-KITCHEN	420	256	55	35	Chrome
	Triflow Mini	TF-MINI	258	120	55	20-35	Black Grey Red
ORIGINALS	Whitehall	TF-KT32C TF-KT32U	380	237	60	35	Chrome Nickel Pewter
	Newton	TF-KT34U	375	235	54	35	Chrome Nickel Pewter
	Churchill C	TF-KT33C	383	237	60	35	Chrome Nickel Pewter
	Livingstone	TF-KT40C	376	237	60	35	Chrome Nickel Pewter

All measurements in mm





You can contact us between 8.30am - 5pm Monday to Thursday. 8.30am - 4pm Friday  
0800 999 3959 | [info@triflowconcepts.com](mailto:info@triflowconcepts.com)